



# Powerful Lifting Partner

## Contents

About Sayal Crane	4
Double, Single Girder and Portal Cranes	6
Hoists Specifications	8
Process Cranes	9
Trolley Hoists (3.2-25 Ton)	10
Trolley Hoists (32-63 Ton)	12
Monorail Hoists (3.2-20 Ton)	14
End-Carriages Double Girder	16
End-Carriages Single Girder	18
Crane Kits	20
Quality Control Process	22
Workflow	24
SAYAL Headquarter and Factory	25
Produce Solutions Suitable for Your Facilities	26



# Double, Single Girder and Portal Cranes

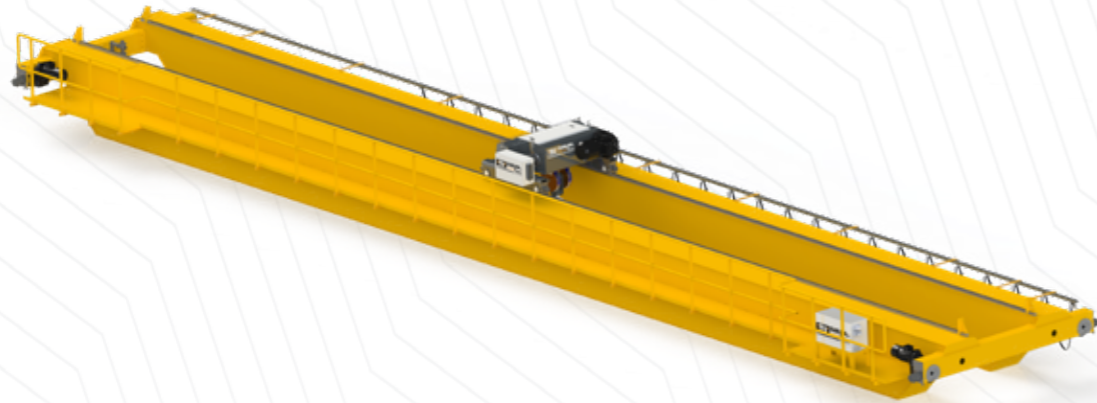

## Double Girder Overhead Travelling Cranes

Double girder overhead travelling cranes are composed of lifting trolleys and end-carriages on two box girders which are manufactured from sheet metal with welding processes. With standard production from 2 ton to 63 tons, and process cranes from 50 to 250 tons we count with effective solutions for wide spans and high lifting capacities. Thanks to the maintenance platform available in one side of the girder, maintenance and fault conditions solving are facilitated. Generally, the main energy supply is provided by the bus-bar system, and the lifting group power line is provided by the c-profile or IPN profile system.

## Single Girder Overhead Travelling Cranes

Single girder overhead travelling cranes consist of lifting trolleys and end-carriages on a steel construction made of box beams or prefabricated steel beams (HEA, HEB, IPN, etc.). It is generally preferred for low lifting capacities and short girder spans. Although it is an effective solution for low headroom between the ceilings and crane runway, it is advantageous in terms of initial investment cost. Generally, the main energy supply is provided by the bus-bar system, and the monorail lifting group power line is provided by the c profile or the moving cable channel. This type is preferred in many areas of the industry like: manufacturing, assembly lines, paint booths and over-the-counter material loading.

## Portal and Semi-Portal Cranes

Portal Cranes are commonly used in open areas. Portal cranes are perfectly designed to handle higher capacity and are suitable for big girder spans. Portal cranes move on rails installed on the ground. Which consists of carrier legs which are mounted to crane girder. Therefore there is no need for any building construction. Portal or Semi Portal cranes are commonly used for heavy fabrication, or in some type of outdoor stock areas, such as hydroelectric power plants, dams, marble quarry, stock yards, harbours etc. sectors.



# Hoists Specifications



- Standardized double-speed motor-gear box system with top-notch German technology and inverter for hoisting trolley and traveling movements.
- Soft lifting and lowering movement with PLC control.
- Soft start option managed by PLC unit (prevents breakage of motor against continuous start-and-stop commands).
- Lifting brake with one million click warranty.
- Soft acceleration with frequency inverter.
- Overload limitation with load-cell unit.
- IP65 protection class.
- Plastic rope guide which is specially designed to ensure long working life, installation is practical and minimization of the damage caused by the broken of the rope guide parts to the personnel working under the crane.
- Joint-connection body-end-carriages.
- Trolley Wheels with ASTM A536 120-90-02 quality casting.
- Limit switches which assure the double stage (slow down-stop) of the hoist movements (Trolley, lifting and down movements).
- Rotating switches which limit the lower-top lift movement.
- Pendant controller with emergency stop button with 48 VAC.
- Phase protection relay, PTC- Protection against overheating for the lifting motor.
- Over-current protection with thermal magnetic protection.
- Optional load display indicator.
- DIN hook and finger protection and handle on the hook block.



# Process Cranes

## Productivity - Safety - Minimum Maintenance

Systems which designed to work at high lifting capacities, high temperatures and speeds, and under heavy working conditions. Engineering calculations and designs are made according to the international working classifications and process. The basic features of process cranes are to ensure the workflow in the most efficient way and safely in the area where they are used, with minimum maintenance requirements.

## Usage Areas;

- Iron-Steel Facilities
- Energy Facilities
- Mine Facilities
- Ports
- Recycling Plants
- Automotive Industry

## General Specifications;

- Motor, gearbox and brake systems designed for heavy conditions in lifting and trolley groups
- Chassis designed with equal load distribution and maximum approach distances according to operating class and conditions
- Twin turn drums designed for central load lifting
- Auxillary lifting systems,
- Load safety brakes,
- Bogie end-carriage systems and wheel bearing houses which make maintenance easier,
- Automatic or manual, central lubrication systems,
- Heavy duty cable trolleys,
- Spring and hydraulic buffers,
- Designs suitable for magnet, polyp or spreader uses,
- Anti-sway systems for prevention of the hook swinging,
- Monitoring fault and service records with PLC,
- Electrical rooms and cabinet cooling systems,
- Operator cabinet and remote control systems



# Trolley Hoists

3,2-25 Ton



## Technical Specifications

TROLLEY HOISTS 3,2-25 TON																			
Capacity (Ton)	Model	CMAA Class	Lifting Height (feet)	Lifting Motor Hp	Lifting Speed, FPM.	Trolley Type	Trolley Motor, Hp	Travelling Speed, FPM.	Reeving	Rope Diameter (in)	h (in)	s (m)	l (in)	c (in)	e (in)	d (in)	m (in)	n (in)	k (in)
3,2	SY.03.AVX-03.07.2.41	D Class	23	0,6 - 4,0	2,3 - 15,4	YG.1612.GF.125	0,75	16,4 - 65,6	4/1	5/16"	19,09	47,24	45,51	55,12	12,99	15,75	12,99	38,19	31,50
	33		51,18									62,99							
	39		59,06									70,87							
	49		70,87									82,68							
5	SY.05.AVX-05.07.2.41	D Class	23	1,3 - 7,9	3,3 - 19,7	YG.1612.GF.125	1,00	16,4 - 65,6	4/1	3/8"	20,47	39,37	51,42	55,12	12,99	19,69	23,62	17,52	37,40
	33		47,24									62,99							
	39		55,12									70,87							
	49		62,99									78,74							
6,3	SY.06.AVX-06.07.2.41	D Class	23	1,3 - 7,9	2,5 - 16,2	YG.1612.GF.125	1,00	16,4 - 65,6	4/1	3/8"	20,47	39,37	51,42	55,12	12,99	19,69	23,23	15,55	37,40
	33		47,24									62,99							
	39		55,12									70,87							
	49		62,99									78,74							
10	SY.10.AVX-10.07.2.41	D Class	23	2,4 - 15,3	2,5 - 16,2	YG.2012.GF.125	1,50	16,4 - 65,6	4/1	9/16"	24,41	39,37	53,39	64,96	12,99	23,62	20,87	13,78	39,37
	33		47,24									72,83							
	39		55,12									80,71							
	49		68,90									94,49							
12,5	SY.12.AVX-12.07.2.41	D Class	23	2,4 - 15,3	2,5 - 16,2	YG.2012.GF.125	1,50	16,4 - 65,6	4/1	9/16"	24,41	39,37	53,39	64,96	12,99	23,62	20,87	13,78	39,37
	33		47,24									72,83							
	39		55,12									80,71							
	49		68,90									94,49							
16	SY.16.AVX-16.07.2.41	D Class	23	3,9 - 25,7	2,4 - 15,6	YG.2212.GF.160	2,00	16,4 - 65,6	4/1	5/8"	25,59	51,18	65,20	68,90	12,99	27,56	24,80	21,26	47,24
	33		59,06									76,77							
	39		66,93									84,65							
	49		78,74									96,46							
20	SY.20.AVX-20.07.1.41	C Class	23	3,9 - 25,7	2,4 - 15,6	YG.2515.GF.200	2,00	16,4 - 65,6	4/1	3/4"	27,76	55,12	71,50	72,83	13,39	23,23	29,92	24,80	51,18
	33		62,99									80,71							
	39		70,87									88,58							
	49		86,61									104,33							
	SY.20.AVX-20.07.3.41	E Class	23	4,7 - 30,3	2,4 - 15,7	YG.2515.GF.200	2,00	16,4 - 65,6	4/1	3/4"	29,92	55,12	71,50	72,83	13,39	26,38	25,59	18,50	51,18
	33		55,12									72,83							
	39		62,99									82,68							
	49		78,74									98,43							
25	SY.25.AVX-25.07.2.41	D Class	23	4,7 - 30,3	2,4 - 15,7	YG.2515.GF.200	3,00	16,4 - 65,6	4/1	3/4"	29,92	55,12	71,50	72,83	13,39	26,38	25,59	18,50	51,18
	33		55,12									72,83							
	39		62,99									82,68							
	49		78,74									98,43							

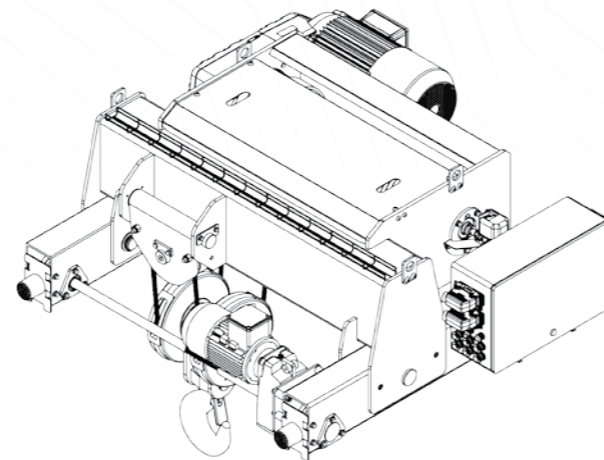
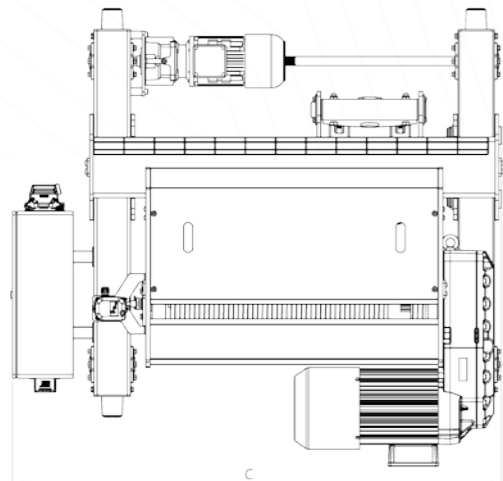
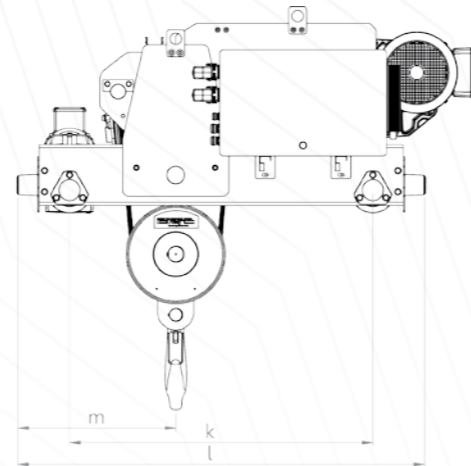
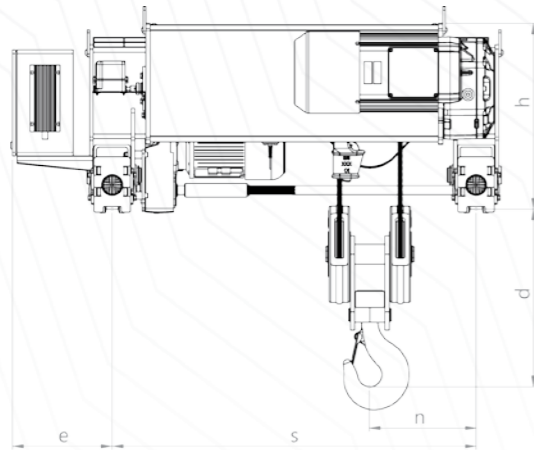

# Trolley Hoists

32-63 Ton

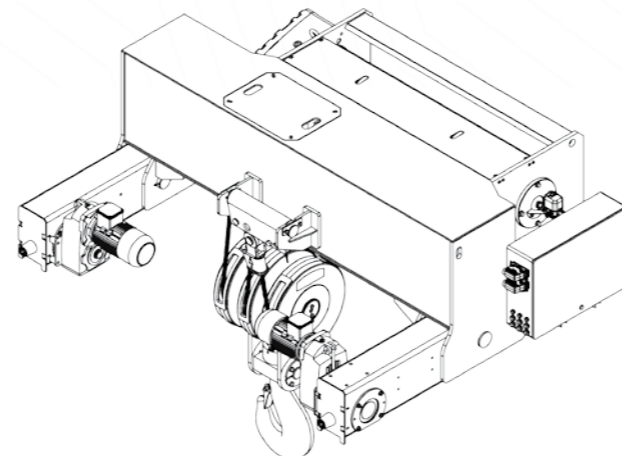
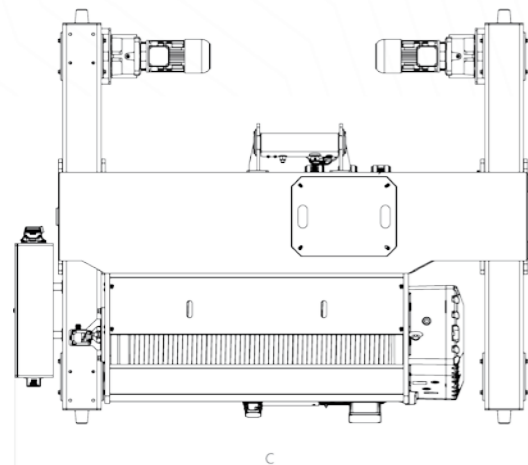
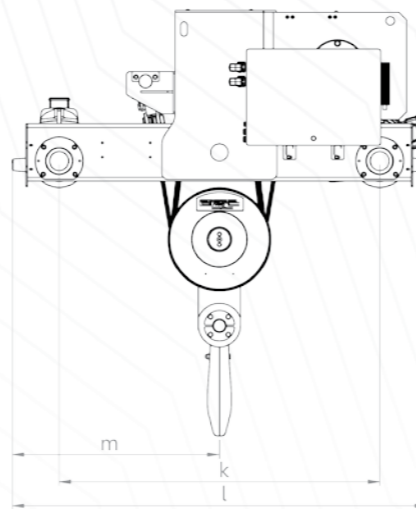
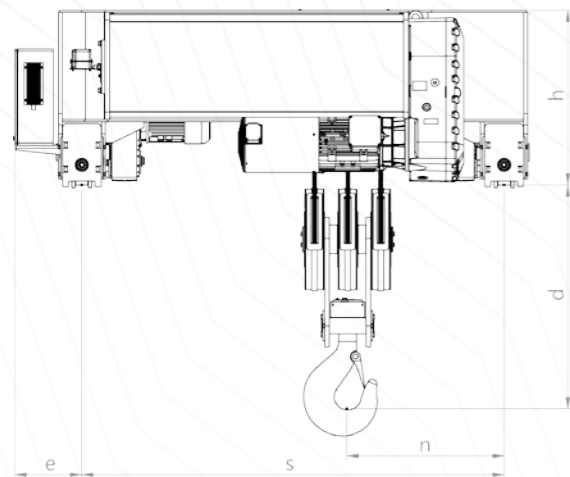
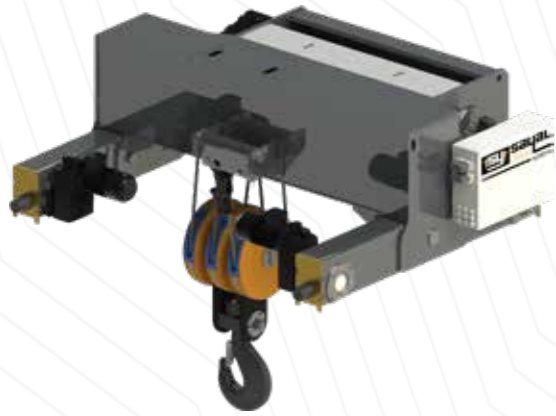

## Technical Specifications

TROLLEY HOISTS 32-63 TON																			
Capacity (Ton)	Model	CMAA Class.	Lifting Height (feet)	Lifting Motor Hp	Lifting Speed, FPM.	Trolley Type	Trolley Motor, Hp	Travelling Speed, FPM.	Reeving	Rope Diameter (in)	h (in)	s (in)	l (in)	c (in)	e (in)	d (in)	m (in)	n (in)	k (in)
32	SY.32.AVX-32.07.2.61	D Class	23	4,7 - 30,3	1,6 - 10,3	YG.3020.GF.250	2x2	16,4 - 65,6	6/1	3/4"	31,50	70,87	77,40	92,52	16,93	39,37	33,86	31,50	55,91
	SY.32.AVX-32.10.2.61		70,87									92,52							
	SY.32.AVX-32.12.2.61		78,74									100,39							
	SY.32.AVX-32.15.2.61		98,43									116,14							
	SY.40.AVX-40.07.2.61		78,74									106,30							
40	SY.40.AVX-40.10.2.61	D Class	23	8 - 32,4	2,6 - 10,4	YG.3020.GF.250	2x2	16,4 - 65,6	6/1	7/8"	37,40	86,61	87,24	106,30	16,93	47,24	43,31	33,46	65,75
	SY.40.AVX-40.12.2.61		94,49									114,17							
	SY.40.AVX-40.15.2.61		110,24									122,05							
	SY.50.AVX-50.07.2.61		78,74									98,43							
	SY.50.AVX-50.10.2.61		86,61									106,30							
50	SY.50.AVX-50.12.2.61	D Class	33	0 - 10,6	0 - 10,6	YG.3220.GP.315	2x3	16,4 - 65,6	6/1	1"	39,37	86,61	87,80	106,30	19,69	55,12	43,31	31,50	61,02
	SY.50.AVX-50.15.2.61		98,43									118,11							
	SY.63.AVX-63.07.1.61		78,74									98,43							
	SY.63.AVX-63.10.1.61		86,61									106,30							
	SY.63.AVX-63.12.1.61		98,43									118,11							
63	SY.63.AVX-63.15.1.61	C Class	23	0 - 10,6	0 - 10,6	YG.3220.GP.315	2x3	16,4 - 65,6	6/1	1"	39,37	78,74	87,80	98,43	19,69	55,12	43,31	33,46	61,02
	SY.63.AVX-63.10.1.61		86,61									106,30							
	SY.63.AVX-63.12.1.61		98,43									118,11							
	SY.63.AVX-63.15.1.61		118,11									137,80							



# Monorail Hoists

3,2-20 Ton

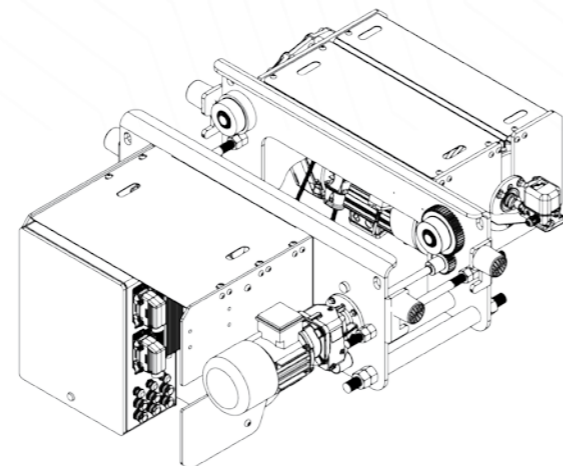
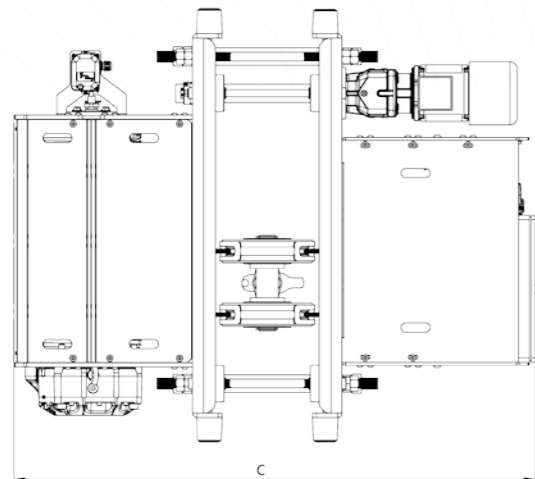
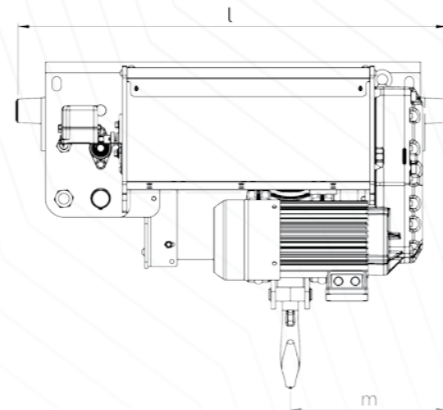
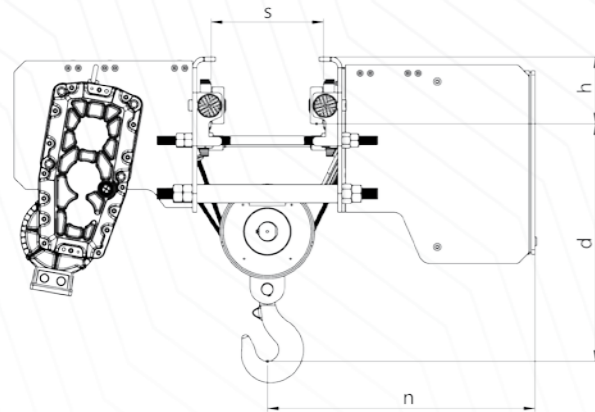
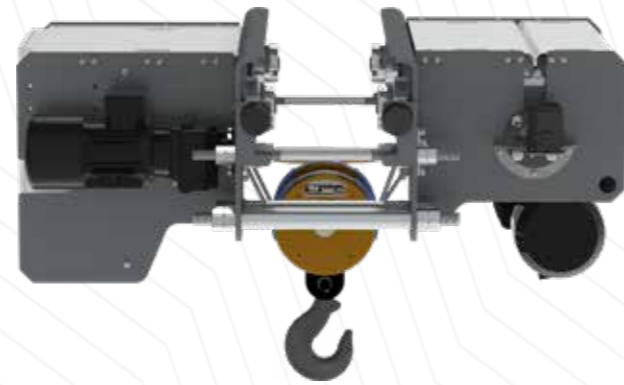

## Technical Specifications

MONORAIL HOISTS																
Capacity (Ton)	Model	CMAA Class	Lifting Height (feet)	Lifting Motor Hp	Lifting Speed, FPM	Trolley Motor, Hp	Travelling Speed, FPM	Reeving	Rope Diameter (in)	h (in)	s (in)	l (in)	c (in)	d (in)	m (in)	n (in)
3,2	SY.03.MVX-03.07.2.41	D Class	23	0,6 - 4	2,3 - 15,4	0,75	16,4 - 65,6	4/1	5/16"	6,30	5,91 - 13,78	51,18	53,15 - 61,02	25,59	15,75	28,74
	SY.03.MVX-03.10.2.41		33									61,42				
	SY.03.MVX-03.12.2.41		39									68,50				
	SY.03.MVX-03.15.2.41		49									77,95				
5	SY.05.MVX-05.07.2.41	D Class	23	1,3 - 7,9	3,3 - 19,7	1	16,4 - 65,6	4/1	3/8"	7,28	5,91 - 13,78	41,14	55,91 - 63,78	25,59	17,13	28,74
	SY.05.MVX-05.10.2.41		33									46,26				
	SY.05.MVX-05.12.2.41		39									50,59				
	SY.05.MVX-05.15.2.41		49									55,91				
6,3	SY.06.MVX-06.07.2.41	D Class	23	1,3 - 7,9	2,5 - 16,2	1	16,4 - 65,6	4/1	3/8"	7,28	5,91 - 13,78	44,29	55,12 - 62,99	29,53	17,32	28,74
	SY.06.MVX-06.10.2.41		33									51,97				
	SY.06.MVX-06.12.2.41		39									58,27				
	SY.06.MVX-06.15.2.41		49									65,35				
10	SY.10.MVX-10.07.2.41	D Class	23	2,4 - 15,3	2,5 - 16,2	1,5	16,4 - 65,6	4/1	9/16"	7,87	5,91 - 13,78	52,36	59,84 - 67,72	27,56	18,70	29,53
	SY.10.MVX-10.10.2.41		33									59,84				
	SY.10.MVX-10.12.2.41		39									66,14				
	SY.10.MVX-10.15.2.41		49									73,62				
12,5	SY.12.MVX-12.07.2.41	D Class	23	2,4 - 15,3	2,5 - 16,2	1,5	16,4 - 65,6	4/1	9/16"	7,87	5,91 - 13,78	52,36	59,84 - 67,72	27,56	18,70	29,53
	SY.12.MVX-12.10.2.41		33									59,84				
	SY.12.MVX-12.12.2.41		39									66,14				
	SY.12.MVX-12.15.2.41		49									73,62				
16	SY.16.MVX-16.07.2.41	D Class	23	3,9 - 25,7	2,4 - 15,6	2	16,4 - 65,6	4/1	5/8"	7,87	5,91 - 17,72	59,45	60,63 - 72,44	29,53	22,44	29,53
	SY.16.MVX-16.10.2.41		33									66,93				
	SY.16.MVX-16.12.2.41		39									73,23				
	SY.16.MVX-16.15.2.41		49									79,53				
20	SY.20.MVX-20.07.1.41	C Class	23	3,9 - 25,7	2,4 - 15,6	2	16,4 - 65,6	4/1	3/4"	8,66	5,91 - 17,72	66,14	61,81 - 73,62	29,53	23,62	30,71
	SY.20.MVX-20.10.1.41		33									77,56				
	SY.20.MVX-20.12.1.41		39									83,86				
	SY.20.MVX-20.15.1.41		49									90,16				

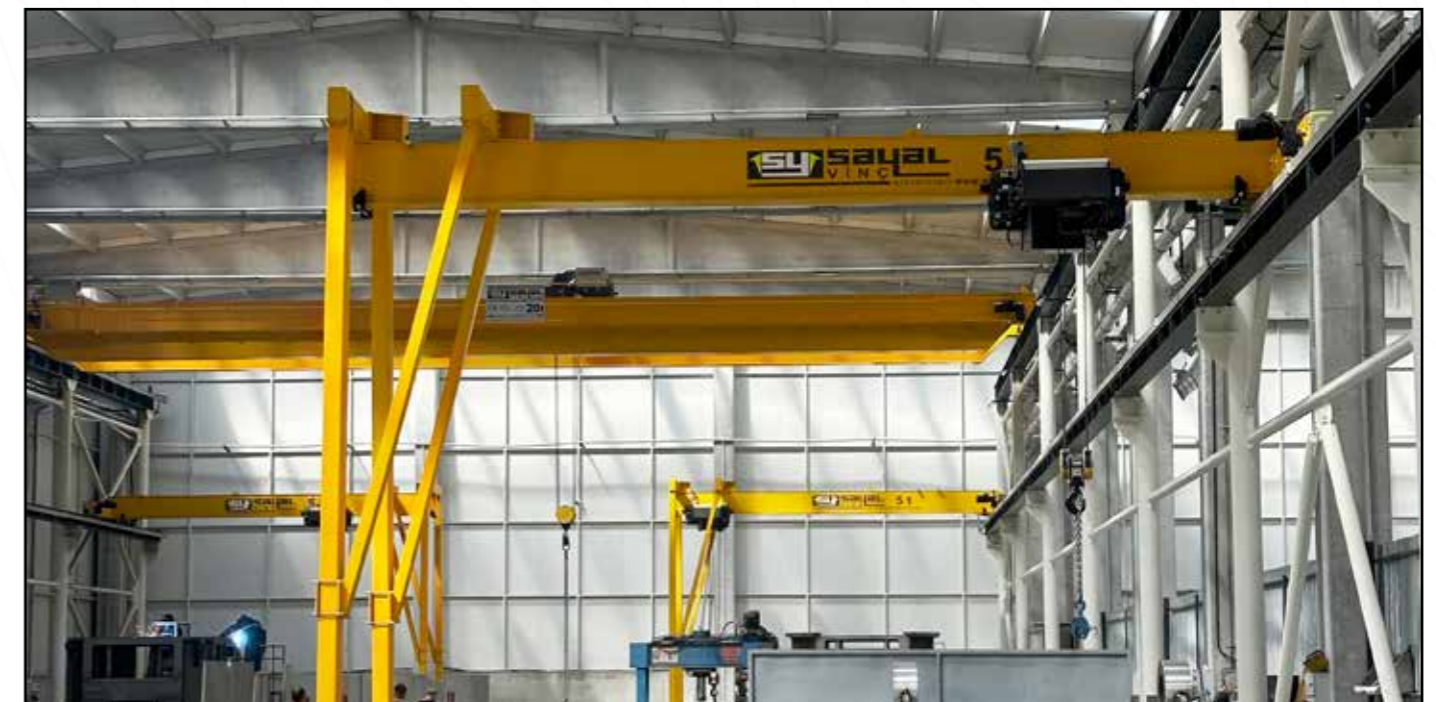

# End-Carriages Double Girder

ton	63	YG.5030.GP.400.6	YG.5030.GP.500.6	YG.4025.GPB.315.6	YG.4525.GPB.400.7	YG.5030.GPB.500.7
	50	YG.4525.GP.400.6	YG.5030.GP.500.6	YG.4025.GPB.315.6	YG.4525.GPB.400.6	
	40	YG.4525.GP.400.6	YG.4525.GP.400.7	YG.5030.GP.500.6	YG.4025.GPB.315.6	
	32	YG.4525.GP.400.5	YG.4525.GP.400.6	YG.4525.GP.400.7		
	25	YG.3020.GF.250.5	YG.4020.GF.315.5	YG.4020.GF.315.6	YG.4525.GP.400.6	
	20	YG.3020.GF.250.4	YG.3020.GF.250.5	YG.4020.GF.315.5	YG.4020.GF.315.6	YG.4525.GP.400.6
	16	YG.2515.GF.200.4	YG.3020.GF.250.4	YG.3020.GF.250.5	YG.4020.GF.315.5	YG.4020.GF.315.6
	12.5	YG.2515.GF.200.4	YG.3020.GF.250.4	YG.3020.GF.250.5	YG.4020.GF.315.5	
	10	YG.2515.GF.200.4	YG.3020.GF.250.4	YG.3020.GF.250.5	YG.4020.GF.315.5	
	6.3	YG.2212.GF.160.4	YG.2515.GF.200.4	YG.3020.GF.250.4		
	5.0	YG.2212.GF.160.4	YG.2515.GF.200.4	YG.3020.GF.250.4		
	3.2	YG.2012.GF.125.3	YG.2212.GF.160.4	YG.2515.GF.200.4	YG.3020.GF.250.4	
	2.0	YG.2012.GF.125.3	YG.2212.GF.160.4	YG.2515.GF.200.4		
	1.6	YG.2012.GF.125.3	YG.2212.GF.160.4	YG.2515.GF.200.4		

Span L (feet)

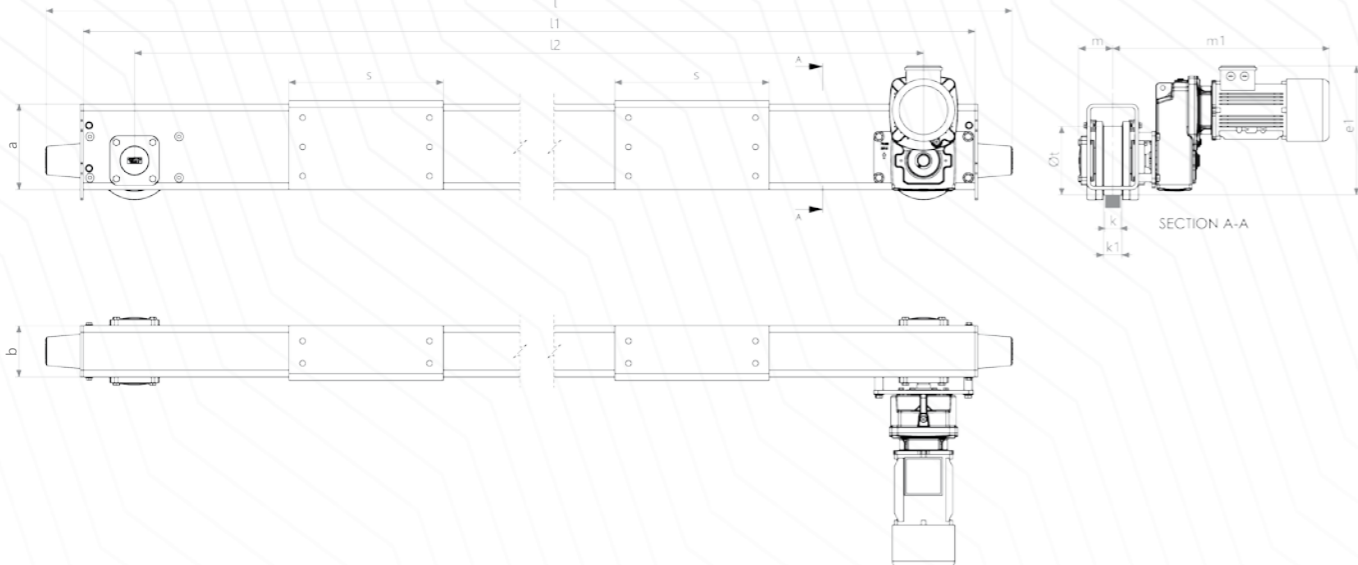

END-CARRIAGES DOUBLE GIRDER													
Model	Wheel (in)	Capacity (kip)	a (in)	b (in)	l (in)	l1 (in)	l2 (in)	s (in)	m (in)	m1 (in)	e1 (in)	k (in)	k1 (in)
YG.2012.GF.125.3	5"	17	8"	5"	82,13 - 101,81	78,74 - 98,43	70,87 - 90,55	15,75 - 21,65	3,15	24,41	14,17	1,18	1,57
YG.2012.GF.125.4												1,57	1,97
YG.2212.GF.160.4	6 1/2"	26	8 5/8"	5"	82,13 - 101,81	78,74 - 98,43	66,93 - 86,61	15,75 - 21,65	3,35	24,41	14,17	1,57	2,05
YG.2515.GF.200.4	8"	40	10"	6"	106,93 - 126,61	98,43 - 118,11	86,61 - 106,30	15,75 - 21,65	4,13	24,80	14,76	1,57	2,13
YG.2515.GF.200.5												1,97	2,52
YG.3020.GF.250.4	10"	66	12"	8"	106,93 - 146,30	98,43 - 137,80	85,43 - 124,80	19,69 - 25,59	5,12	25,59	15,75	1,57	2,13
YG.3020.GF.250.5												1,97	2,52
YG.4020.GF.315.5	12 1/2"	66	16"	8"	128,98 - 168,35	118,11 - 157,48	102,36 - 141,73	19,69 - 25,59	5,12	25,98 - 29,53	19,69	1,97	2,52
YG.4020.GF.315.6												2,36	2,91

## The Benefits at Sayal Crane End Carriages;

- Design for single and double girder overhead cranes
- Minimum approach dimensions
- Various connection possibilities
- Wheels in grey cast iron ASTM A536 120-90-02 up to size 12 1/2"
- For special applications, AISI 4140 alloy steel wheels
- Splined shaft connection

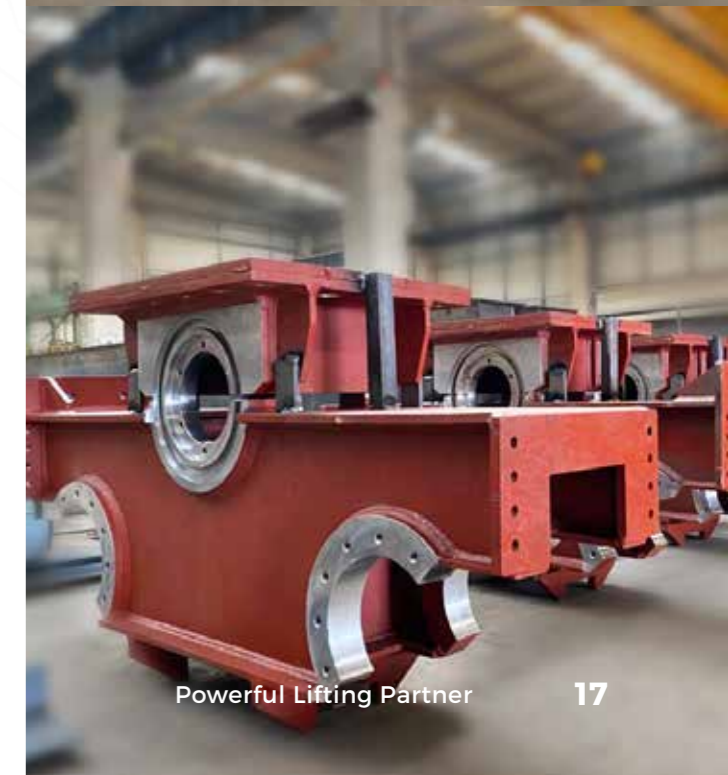

# End-Carriages Single Girder

ton	20	YG.3020.GF.250.4		YG.3020.GF.250.5				YG.4020.GF.315.5		YG.4020.GF.315.6		YG.4525.GP.400.6																		
	16	YG.2515.GF.200.4		YG.3020.GF.250.4		YG.3020.GF.250.5				YG.4020.GF.315.5		YG.4020.GF.315.6																		
	12.5	YG.2515.GF.200.4				YG.3020.GF.250.4		YG.3020.GF.250.5		YG.4020.GF.315.5																				
	10	YG.2515.GF.200.4				YG.3020.GF.250.4		YG.3020.GF.250.5		YG.4020.GF.315.5																				
	6.3	YG.2212.GF.160.4				YG.2515.GF.200.4				YG.3020.GF.250.4																				
	5.0	YG.2212.GF.160.4				YG.2515.GF.200.4				YG.3020.GF.250.4																				
	3.2	YG.2012.GF.125.3		YG.2212.GF.160.4		YG.2515.GF.200.4				YG.3020.GF.250.4																				
	2.0	YG.2012.GF.125.3		YG.2212.GF.160.4				YG.2515.GF.200.4																						
	1.6	YG.2012.GF.125.3		YG.2212.GF.160.4				YG.2515.GF.200.4																						
		3	7	10	13	16	20	23	26	30	33	36	39	43	46	49	52	56	59	62	66	69	72	75	79	82	85	89	92	95

Span L (feet)

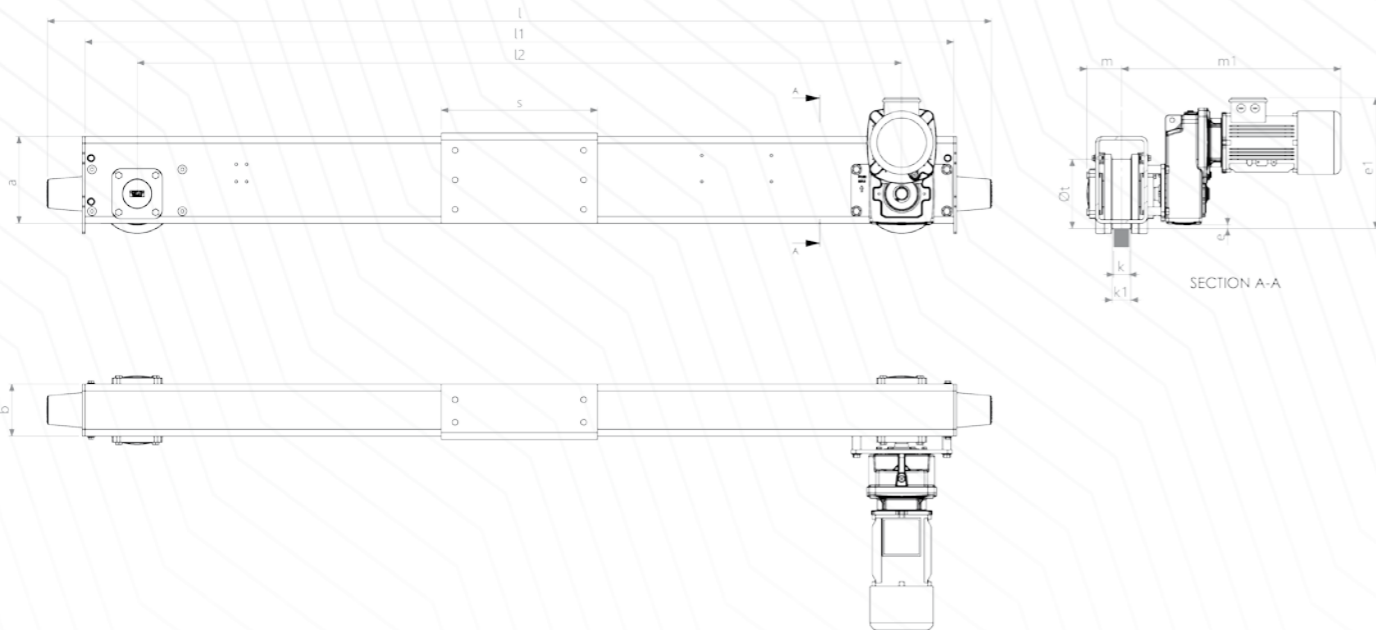

## The Benefits at Sayal Crane End Carriages;

- Wheel diameters in 9 sizes from 5" – 28"
- Profile-section design up to size 15 ¾"
- Welded box-section design from size 15 ¾"
- Standard derailment guard
- High-performance travel motors and gear-boxes
- End carriage accessories: e.g. buffers, horizontal guide rollers, track sweeps.



END-CARRIAGES SINGLE GIRDER													
Model	Wheel (in)	Capacity (kip)	a (in)	b (in)	l (in)	l1 (in)	l2 (in)	s (in)	m (in)	m1 (in)	e1 (in)	k (in)	k1 (in)
YG.2012.GF.125.3	5"	17	8"	5"	62,44 - 82,13	59,06 - 78,74	51,18 - 70,87	15,75 - 21,65	3,15	24,41	14,17	1,18	1,57
YG.2012.GF.125.4												1,57	1,97
YG.2212.GF.160.4	6 ½"	26	8 ¾"	5"	62,44 - 82,13	59,06 - 78,74	47,24 - 66,93	15,75 - 21,65	3,35	24	14,17	1,57	2,05
YG.2515.GF.200.4	8"	40	10"	6"	87,24 - 106,93	78,74 - 98,43	66,93 - 86,61	15,75 - 21,65	4,13	24,80	14,76	1,57	2,13
YG.2515.GF.200.5												1,97	2,52
YG.3020.GF.250.4	10"	66	12"	8"	87,24 - 126,61	78,74 - 118,11	65,75 - 105,12	19,69 - 25,59	5,12	25,59	15,75	1,57	2,13
YG.3020.GF.250.5												1,97	2,52
YG.4020.GF.315.5	12 ½"	66	16"	8"	109,29 - 148,66	98,43 - 137,80	82,68 - 122,05	21,65 - 29,53	5,12	25,98 - 29,53	19,69	1,97	2,52
YG.4020.GF.315.6												2,36	2,91

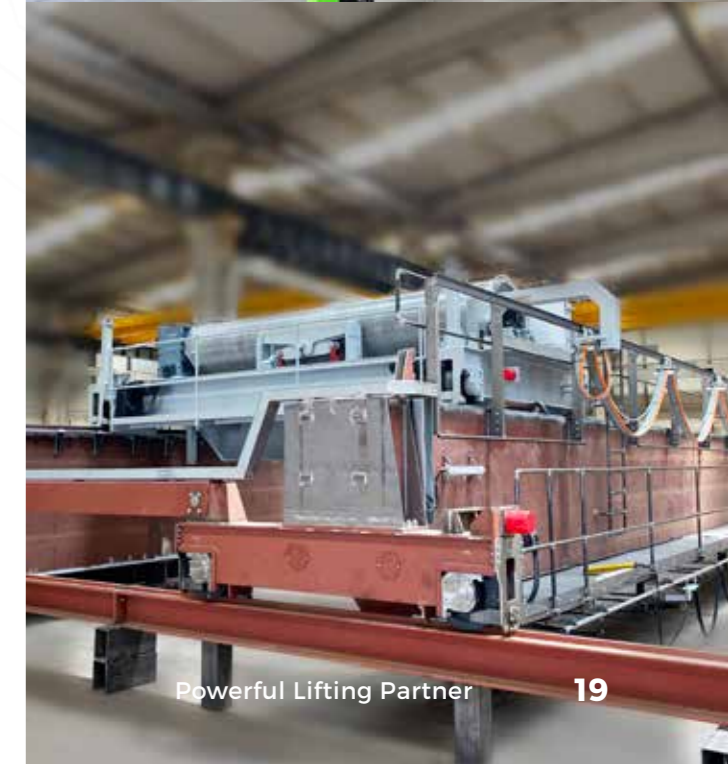

# Crane Kits

SAYAL CRANE KITS; includes all components that make up an overhead crane, except the crane girders. Crane kits provide economic advantages especially for companies who are producing cranes and girder constructions and for our dealers all around the world. Crane kits are preferred due to their advantages such as easy assembly, convenient transportation and fast delivery.



Busbar and Current Collector



End Carriages with Mounting Plates, Bolts and Buffers



Girder Travelling Gear-Boxes



Switch, Sensor And Tow Arms

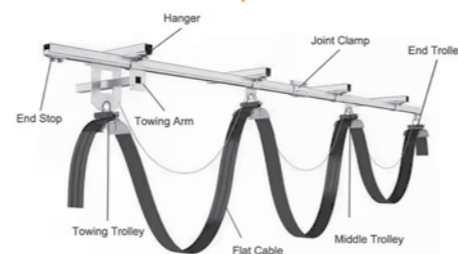

Trolley Energy Supply Line (Festoon or Cable Track)

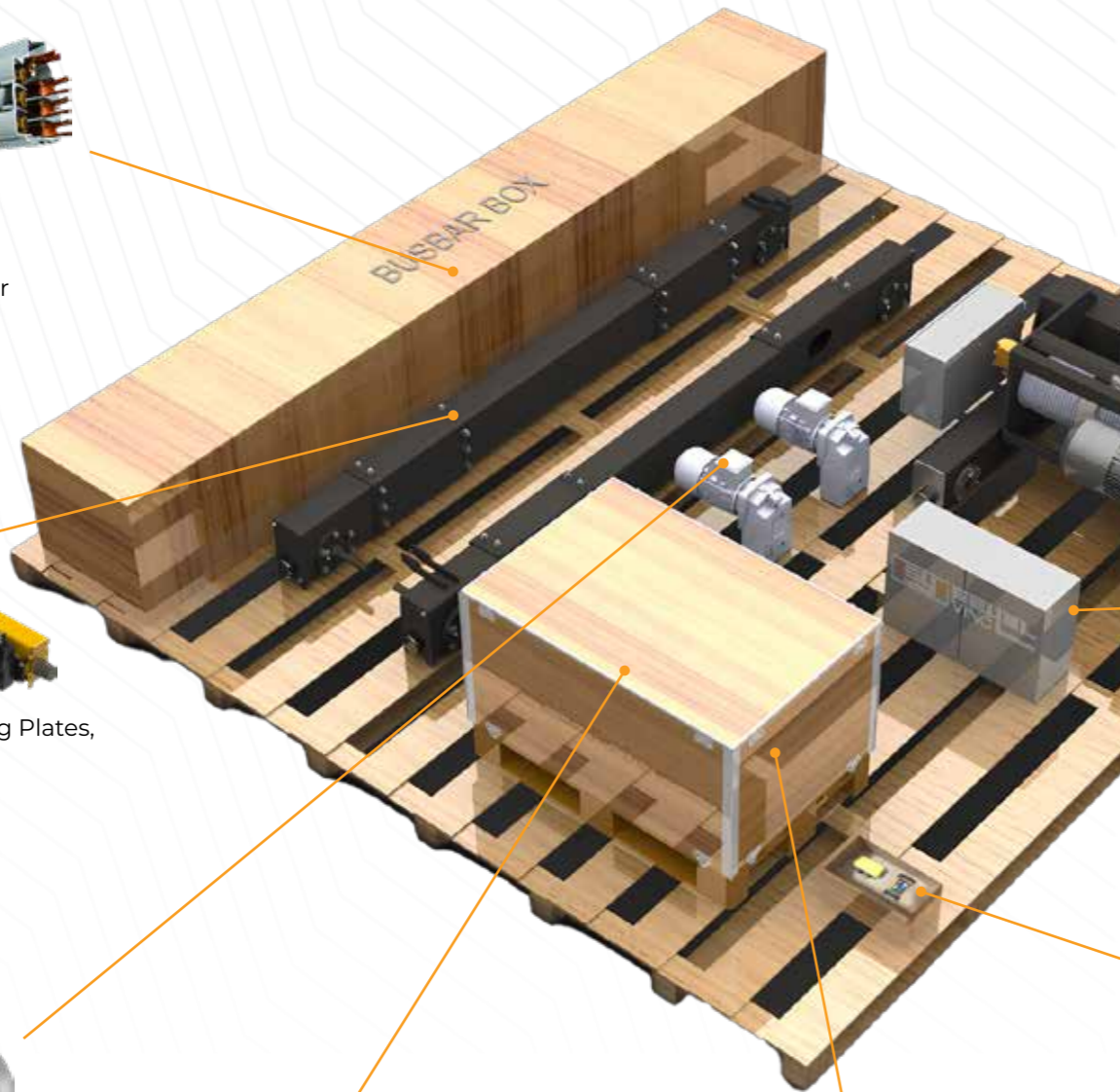

Hoist and Hoist Control Panel (Monoray or Double)



Girder Travelling Control Panels



Remote Control





## INCOMING QUALITY CONTROL

- Dimension Inspection
- Material Certificate Control
- Material Preparation and Inspection:
  1. Non-destructive testing (VT,PT,MT,UT)
  2. Mechanical Test;
    - 2.1 Hardness
    - 2.2 Tensile Strength
    - 2.3 Yield Strength
    - 2.4 Elongation

## PROCESS QUALITY CONTROL

1. **Machining Process Controls;**
  - First Article Inspection (FAI)
  - Periodic Self-Inspection
2. **Machine and Structural Process Control;**
  - Machine and structural process controls are performed in accordance with the Inspection and Test Plan (ITP).
  - Acceptance criteria: EN 1090-2 Execution class 3 (EXC3)
  - Fit-up control (according to the technical drawing).
  - Welding acceptance level: EN ISO 5817 Class B
  - Welding non-destructive testing (VT,PT,MT,UT)
  - Low Voltage Directive Test (LVD) (EN 60204-1)
  - Underwriters Laboratories (UL Certificate)
3. **Paint Process Controls (EN ISO 12944)**

All painted crane components are subjected to paint inspections, and the results are recorded in the Paint Test Report.

  - DIN-cup 4 Viscosity Test (Paint Preparation)
  - Pre-Paint Surface Inspections (According to ISO 8501, ISO 8503).
  - Visual Inspections (Color Comparison, Paint Defects, etc.).
  - Paint thickness Inspection.
  - Cross-Cut Paint Adhesion Test (ISO 2409).

## LOAD TEST AND FINAL CONTROL

- All lifting machines produced within Sayal Crane are subjected to dynamic and static load tests according to EN 15011 standards at a specially designed test station.
- All finished machines and components are subjected to comprehensive inspections by quality technicians.
- The control and test results are recorded in the FINAL INSPECTION FORM.

## SHIPMENT INSPECTION

- All finished crane components and semi-finished parts ready for shipment are inspected according to the checklist before shipment.
- The checklist and photos are recorded in the FINAL INSPECTION FORM.

## SITE DYNAMIC AND STATIC LOAD TEST

After the site assembly, all systems are subjected to load acceptance tests according to TS EN 15011 (Dynamic 1.1, Static 1.25). All measurements and test results are recorded in the FINAL Completion Inspection Form for crane systems

## CERTIFICATE AND QUALIFICATIONS

- TS EN ISO 9001:2008: Quality Management System Certificate – QSI
- ISO 3834-2: Quality Requirements for Fusion Welding of Metallic Materials - TÜV-NORD
- EN 1090-1 & 2 : Execution of Steel Structures and Aluminium Structures - TÜV-NORD
- TS EN 15011 Cranes – Safety – Design and Construction-TSE
- HYB: Hizmet Yeterlilik Belgesi –TSE (Service Qualification Certificate)
- 2006/42/AT Machine Directive Compliance Certificate -TÜV NORD
- -ISO-45001:2008 Occupational Health and Safety Management Systems – QSI
- EAC

# Workflow

# SAYAL Headquarter and Factory



## ENQUIRY

Contact us directly or visit our website [www.sayalcrane.com](http://www.sayalcrane.com) for further information



## TECHNICAL CONSULTANCY

After enquiry, technical meeting is held to understand the customer request and guide the customer for the right choice.



## QUOTATION

Our sales department prepare the offer for high quality product with an affordable price.



## DESIGN

Engineers start their design using Solidworks and Autocad after getting the purchase order which had been prepared by the sales department.



## PRODUCTION

After preparing the manufacturing drawings by our engineering department, manufacture procedures starts taking into considerations the international standards.



## QUALITY CONTROL

During the manufacturing period, our QC specialists follow up with all measurements and Control for the materials and manufacturing steps (cutting, welding, painting, etc)



## PACKAGING AND TRANSPORTATION

FAT is done when the equipments are ready for loading. After FAT, seaworthy packaging and safety loading is done in order for the equipments to take their ways to the customer.



## INSTALLATION

Our installation specialists arrive to the site just before the equipment arrive or as soon as the customer is ready for installation.



## TEST AND COMMISSIONING

Our last but not final step is the test, commissioning and deliver the equipment to the customer by our specialists. After this step, our ASS department follow up with the customer.



# Produce Solutions Suitable for Your Facilities

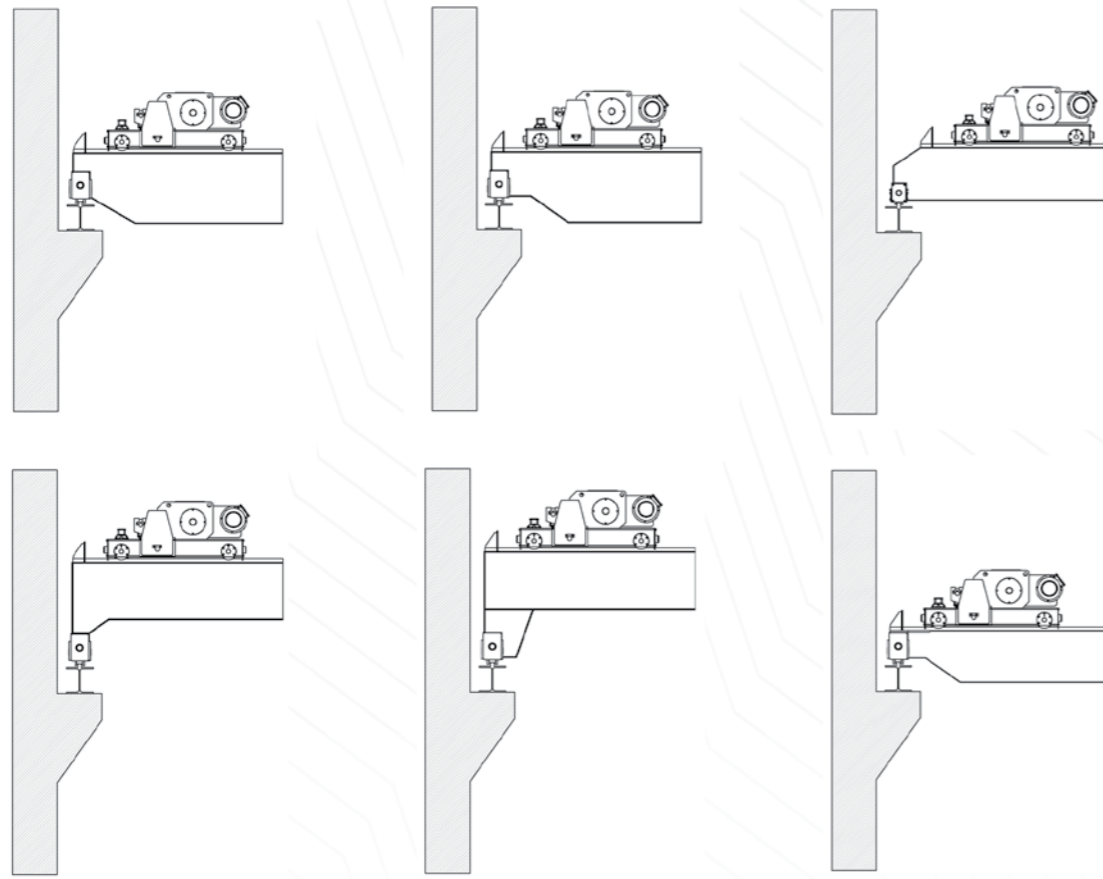



**SAYAL LIFTING SYSTEMS INC.**

11417 IRVING PARK ROAD (IL-19), SUITE B-13-5,  
FRANKLIN PARK - IL 60131 USA

+1(302) 830 30 03

[info@sayallifting.com](mailto:info@sayallifting.com)  
[www.sayallifting.com](http://www.sayallifting.com)